

COFFEE GRINDER #43



Internationally patented models



Silent and sturdy coffee shop grinder

Powerful and easy to use, this shop coffee grinder guarantees a high quality grinding.

Its adjustable setting will allow you to choose the fineness of your grinding: from very fine to coarse.

Equipped with a bag holder, it accepts all types of bags from 250gr to 1kg. It is therefore ideal for roasters, zero waste grocery stores, supermarkets, cafes, etc.

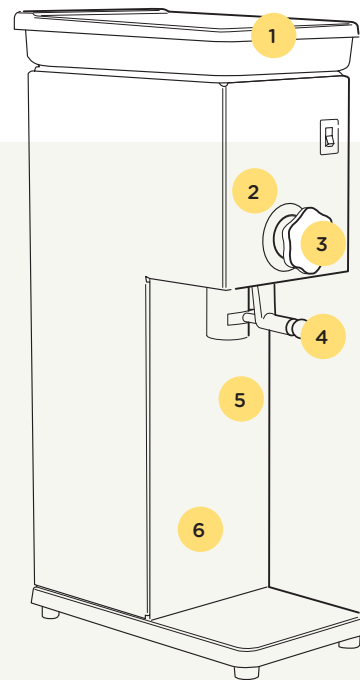

- 1.7 kg (3.8lbs) hopper**
- Ø 63.5mm (2,5") grinding discs: high resistance, long lasting** designed and manufactured by Santos for a high quality grinding
- Precision grinding,** from very fine to coarse. Easy to adjust.
- Bag holder accepting bags from 250g to 1kg** (1/2 pounds to 2 pounds) Maximum bag height: 360 mm
- Stainless steel body**
- Powerful asynchronous motor** 5-year warranty

Output of the coffee grinder #43

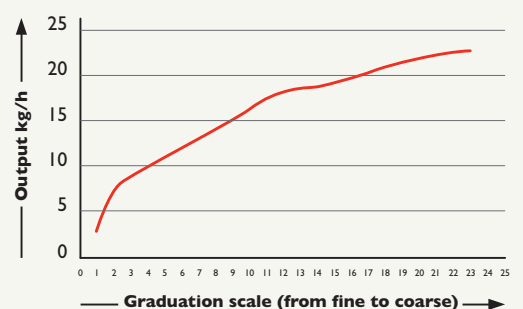

65 YEARS
experience

Santos know how

- Since 1954, Santos manufactures its own grinding discs for a high quality grinding
- Specialist of silent grinders
- Dose regularity
- Not burning coffee while grinding
- Anti-static system
- Easy adjustment and maintenance



Powerful and reliable

Powerful asynchronous and very silent motor.

Sturdy product, adapted to intensive use.

Quality grinding

Easily adjustable grinding settings: precise setting of the grinding fineness for all types of filtration.

Santos manufactures its own grinding discs to give you a perfect grinding, constant and fine.



Safety, Standards, Hygiene

In accordance with the following regulations:	Machinery directive 2006 / 42 / EC
	Electromagnetic compatibility 2014 / 30 / EU
	“Low voltage” directive 2014 / 35 / EU
	RoHS directive 2011 / 65 / EU
	Regulation 1935 / 2004 / EC (contact with food)
	Regulation 10 / 2011 / EU (Plastic in contact with food)

Harmonized European Standards:	EN ISO 12100 : 2010
	EN 60204-1 + A1 : 2009
	EN 60335-2-64 : 2004 Commercial electric kitchen machines
	CE Marking

Thermal Safety	Motor protected by internal thermal detector
-----------------------	--

Acoustic Safety	Very silent and powerful asynchronous motor
------------------------	---

Hygiene	All removable parts can be put in a dishwasher or easily cleaned with hot soapy water.
----------------	--

PRODUCT: 2 YEAR WARRANTY | **MOTOR:** 5 YEARS

Technical specifications

Motor

Single phase:

110-120 V – 50/60 Hz – 650 W – CE

220-240 V – 50/60 Hz – 600 W – CE

Speed:

1500rpm (50Hz)

1800rpm (60Hz)

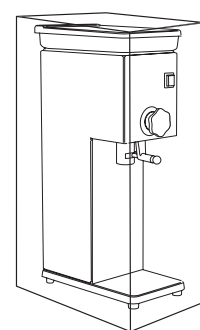
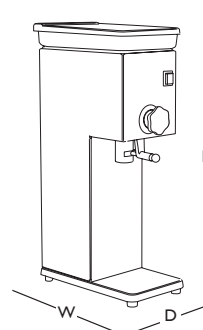

Appliance

D: 190 mm (7.5")

W: 335 mm (14")

H: 690 mm (27")

Weight:

20,6 Kg (44 lbs)

Shipping Box

D: 280 mm (11")

W: 390 mm (15")

H: 760 mm (30")

Weight:

22 Kg (48 lbs)

SANTOS Coffee grinder #43
 From date: 12/2017
 from serial number: 1040812

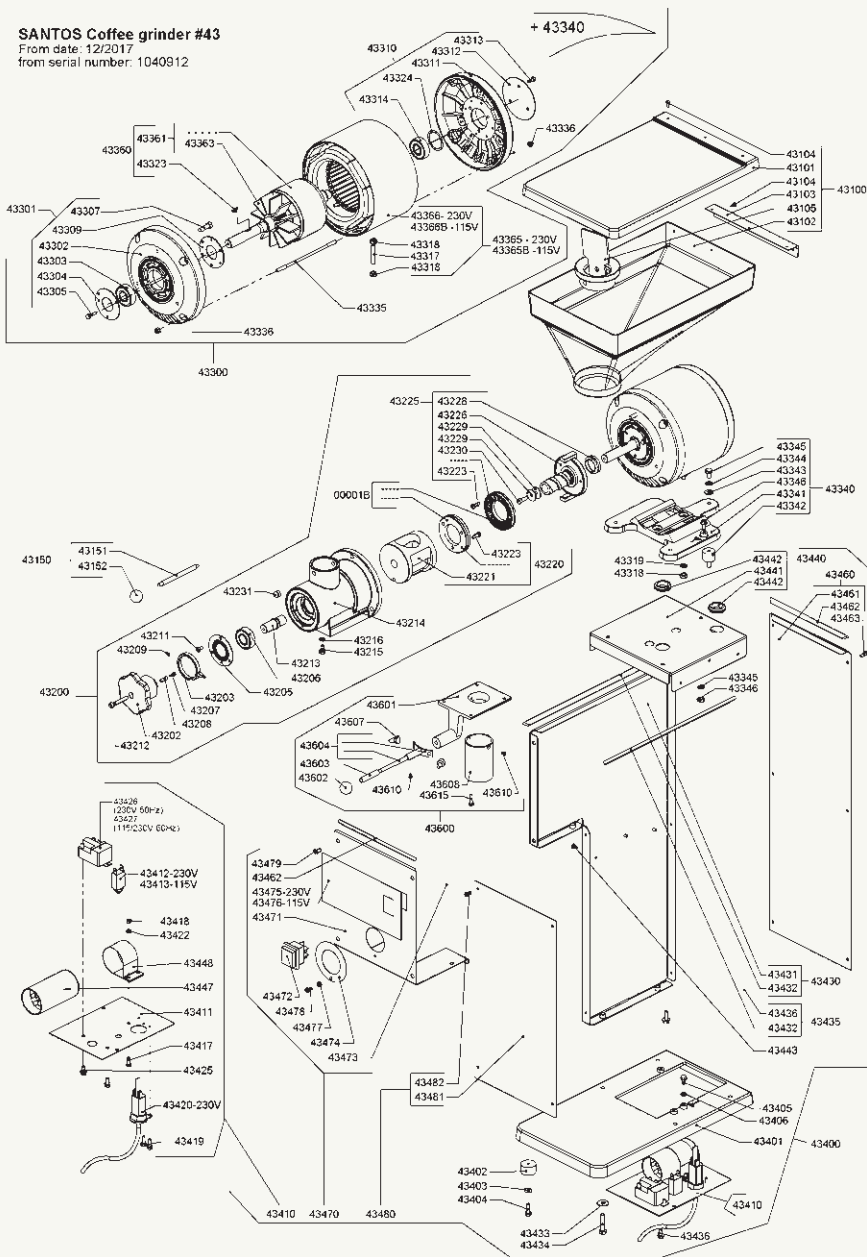

SANTOS
 140-150 avenue Roger Salengro
 BP 80 067
 69511 Vaulx-en-Velin Cedex (Lyon) FRANCE

Tel: +33 472 37 35 29
 Fax: +33 478 26 58 21
 Email: santos@santos.fr
www.santos.fr

Follow us on **#santosaddict**
 social networks

